

HospitalTracks[®]

Cubicle Curtain Systems

Cubicle Curtain Track Installation Guide



Installing Cubicle Curtain Tracks

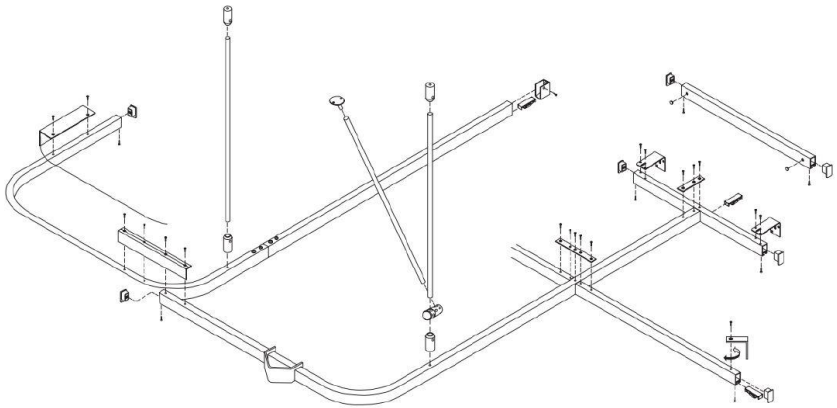

- 1.** Unpack all tracks and components and ensure that all items are included as per delivery note.
- 2.** Using the dimensions on the drawing or the agreed track position, mark the position of the wall shoes on the wall. All dimensions are to the centre of the track. The HTM66 recommended fitting height is 2100mm from the floor to the underside of the track.
- 3.** Assemble each section of the track on a clean floor using inner joiners where applicable.

Tip: When fitting the inner track joiners, tighten the outside screws first and then the inner screws last for the perfect join.

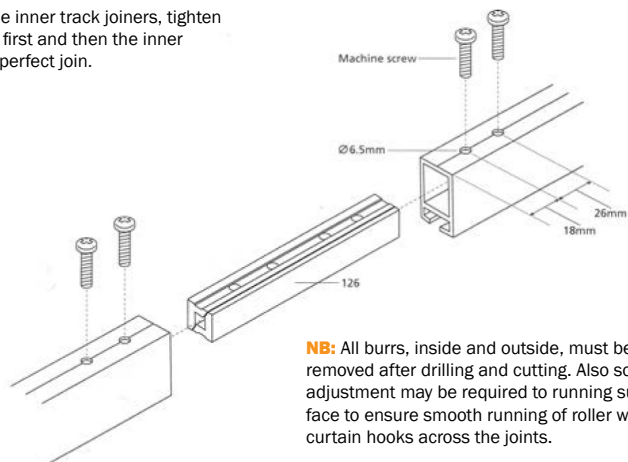

4. Lift first section of track up into wall shoes.
5. Support the track at bend with a suitable temporary support ensuring that track is level.
6. Using the screws provided, secure the track into the wall shoe.

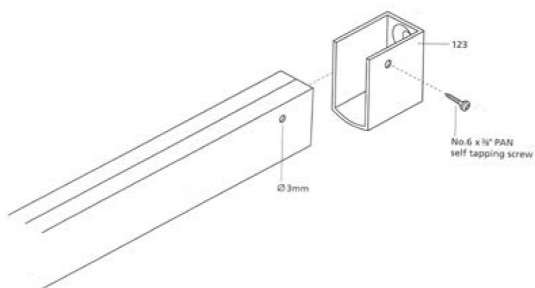

7. Depending on layout of the track, join each section together with overlaps, taking care that all fixing holes are used and screws are tightened securely for maximum stability.

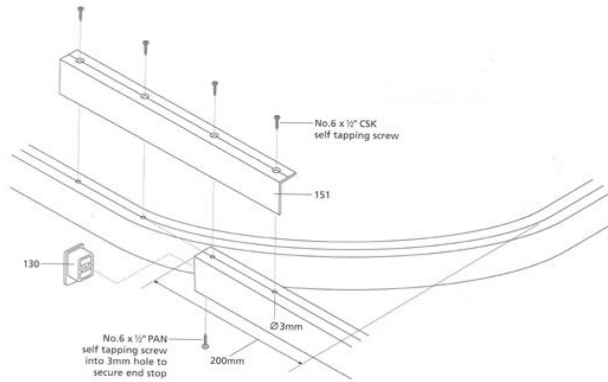

8. For suspension rods refer to Fig. 1. Each bend must be supported by a 313 hanger assembly no further than 350mm from either leg of the bend.

Fig. 1

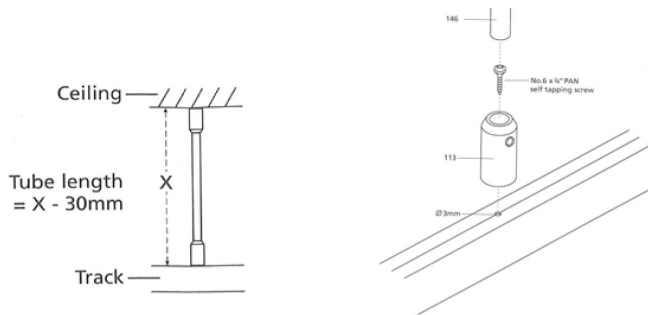

9. At no point should the track span more than 3000mm without support. If the track has a join, ensure the track is suspended within 150mm from the join. If the track has no lateral support and spans more than 3000mm, please ensure a V-hanger is used. Using a plumb line mark where the hanger assembly will fix to the ceiling and track. Refer for Fig. 2

Fig. 2

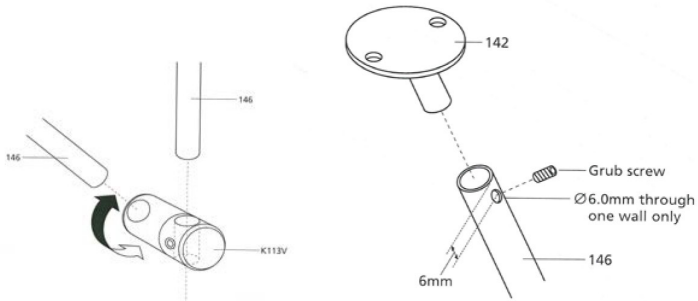

10. For V-suspension, please refer to Fig.2. When assembling the 313 hanger assembly, ensure that the K113 V-hanger is located on the suspension tube and is resting on the lower 113 hanger which is fixed to the track.

11. Once installation is complete, ensure that gliders run smoothly across and join and adjust any misalignments accordingly. The track can be tweaked with a large, flat-headed screwdriver to correct any misalignments on joins if required.

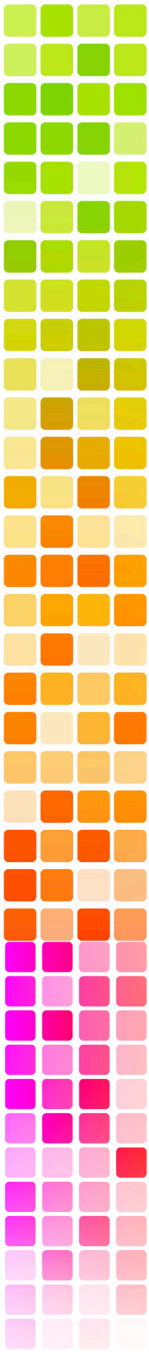

HospitalTracks[®]
Cubicle Curtain Systems

www.hospitaltracks.co.uk | info@hospitaltracks.co.uk