



Fitting Instructions

YewdaleKestrel[®]

Anti-ligature Shower Track (K100)

Part no: 921

What you'll need



Screwdriver



Drill

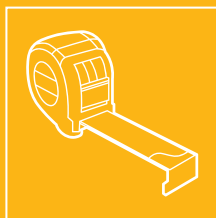

Measuring Tape



Pencil

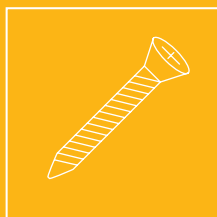

Screws



Wall Plugs

What's in the box



Pre-assembled Track

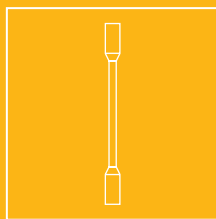

Ceiling Hanger
(optional if L shape or
over 2500mm wide)



3mm Drill Bit

Face Fix Bracket

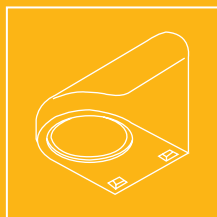

Magnet Housing



Screw Cover

Top Fix Bracket



Magnet Housing

or

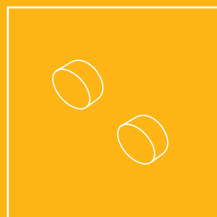

Screw Cover



Warning

All instructions must be read before installing.



Fitting Time

Approx. 20 minutes

Anti-ligature Shower Track Instructions

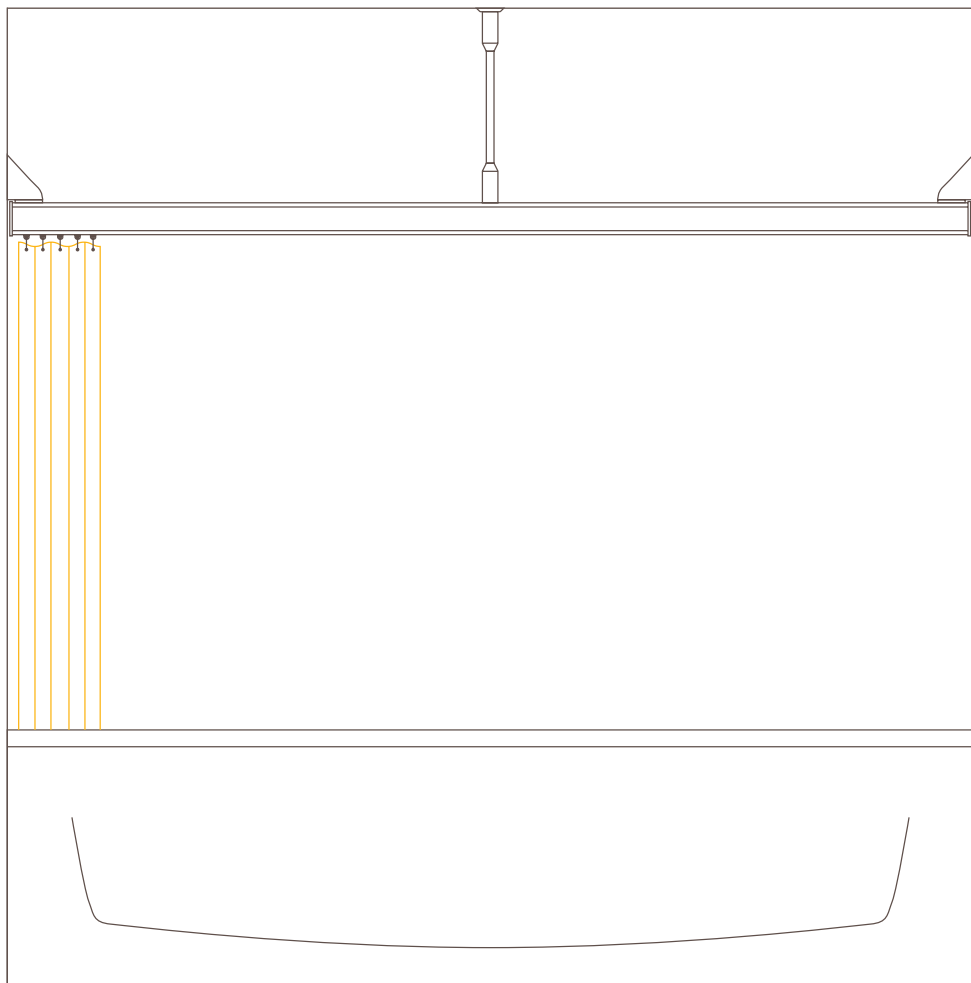

Before Installation

Check the position and height of the track ensuring that the curtain will hang inside the bath or shower tray. The aluminium track should be clear of the wall by 7mm at each end. The track may be trimmed with a hacksaw if necessary.

Anti-ligature Shower Track Instructions

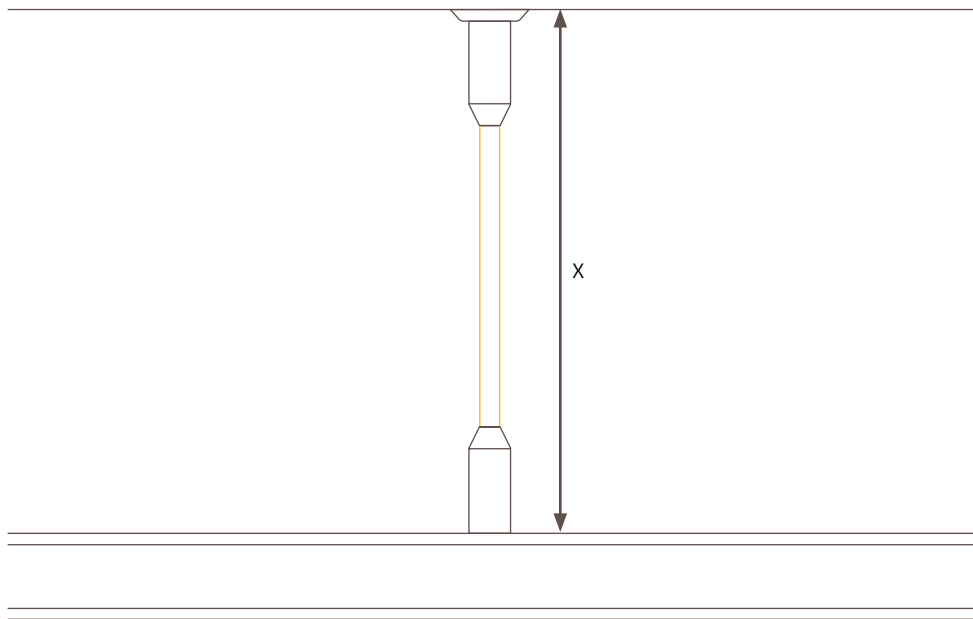

Before Installation

For the correct tube length, you will need to minus (-) 44mm from the overall length of the track to the ceiling (x).

When installing the face fix bracket at either end, the centre of the steel disc must be 25mm from the end of the track.

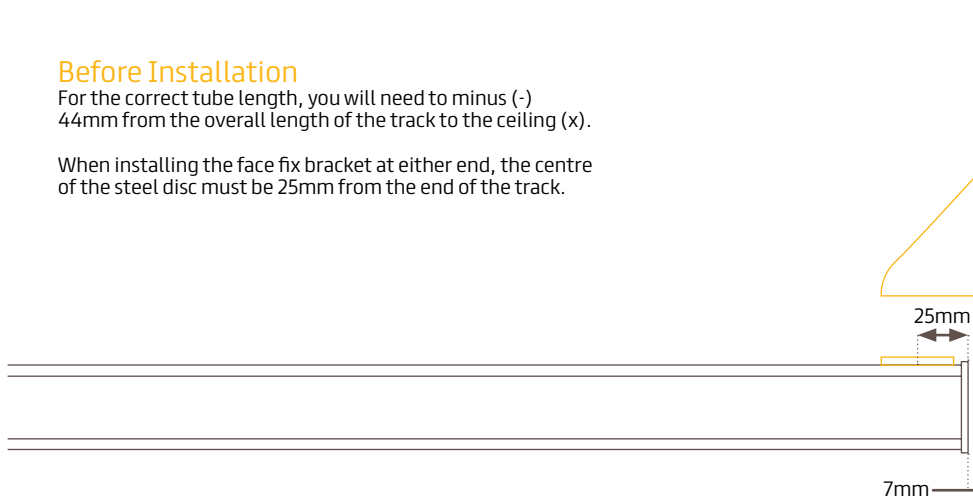

Anti-ligature Shower Track Instructions

- 01** Check position and height of track.

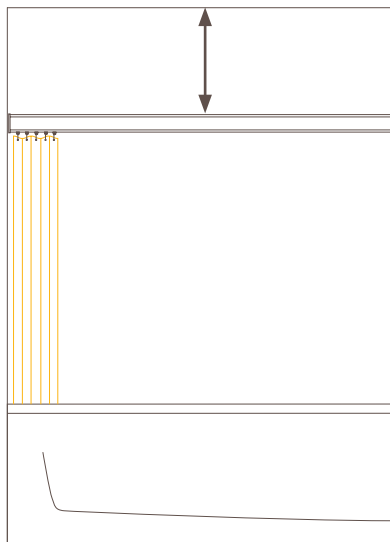

- 02** Position the hanger tube and cut as per diagram on previous page. A hanger assembly **MUST** be on or near each bend. In the case of a U-shape track, a hanger assembly and a U-hanger assembled must be used.

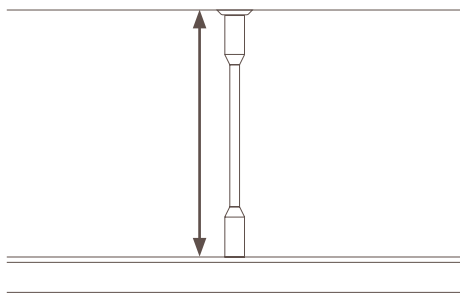

Anti-ligature Shower Track Instructions

- 03** Once you have the correct position. Attach the face fix brackets to either end.

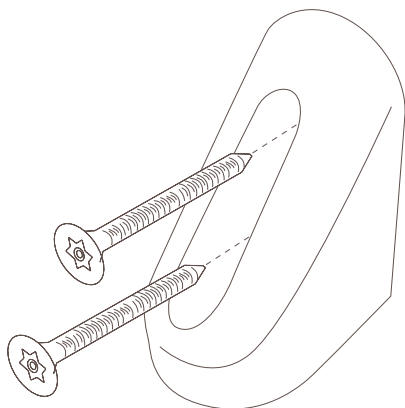

04

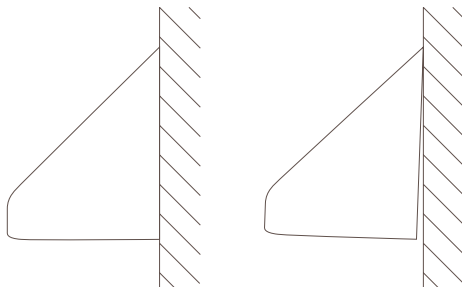

- 05** If necessary, attach the top fix bracket.

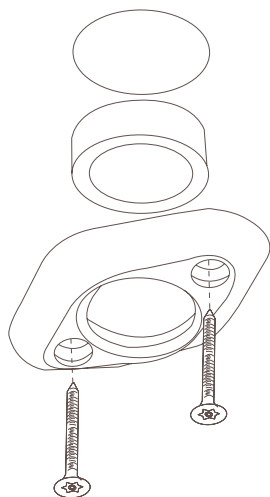

- 06** Screws must not be proud, ensuring no ligature points are left exposed.



Anti-ligature Shower Track Instructions - Face Fix

- 07** The push screw covers **MUST** be fitted ensuring they are flush with the bracket body.

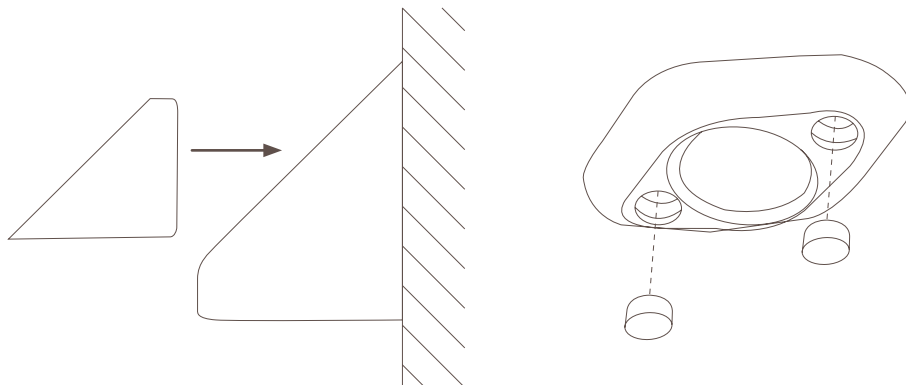

-
- 08** To allow the curtain to stack neatly at one end, a captive hook is retained by a self-tapping screw. This can be repositioned if necessary by drilling another hole in the underside of the track using a 3mm drill bit provided.

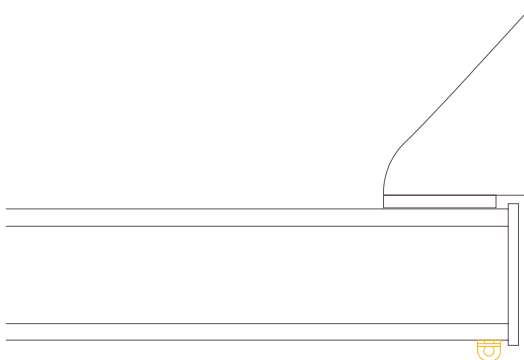

Anti-ligature Shower Track Instructions - Top Fix

09

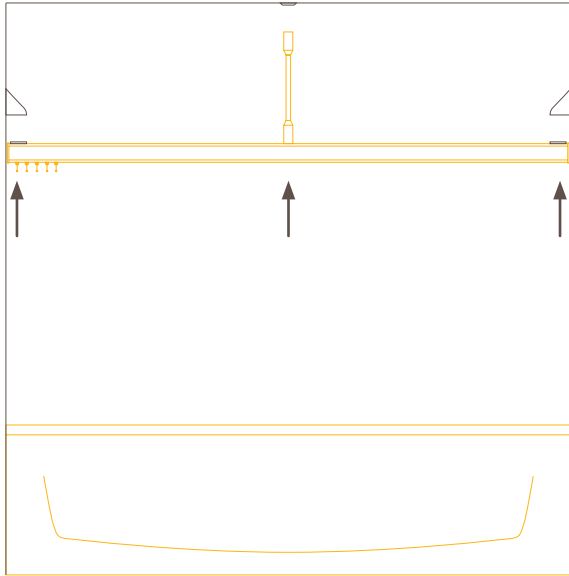

10

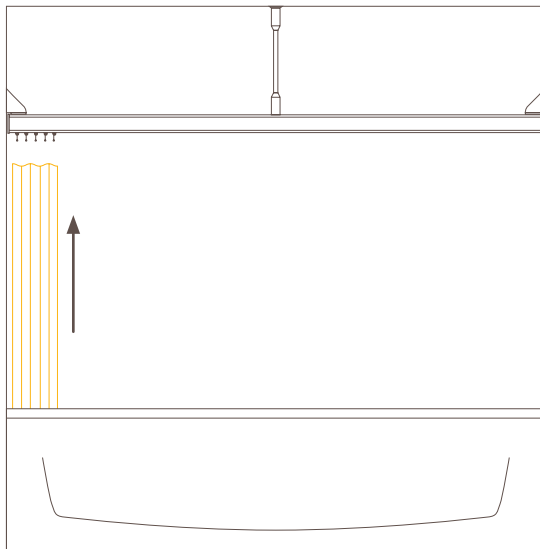

Anti-ligature Shower Track Testing

Testing

Discs should be horizontal and centre of gravity of load should be directly beneath centre-line of discs. Test completed installation. The downward force needed to part the brackets should never be more than 400N (40kg static load) at any point.

Please Note

Care must be taken to ensure that no ligature points are left once the installation has been completed. The push-in screw cover is intended to be tight fit to prevent unauthorized access to fixings.

YewdaleKestrel® Packers (K557PC)

If needed, YewdaleKestrel® Packers (K557PC) can be used. Do Not use any other items to replicate this.

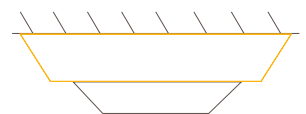
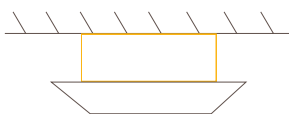
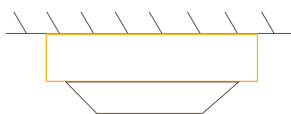
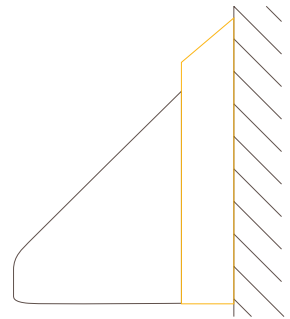
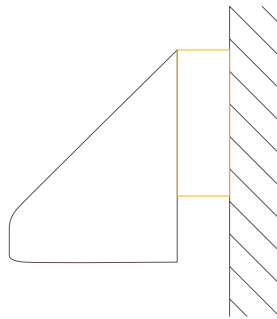
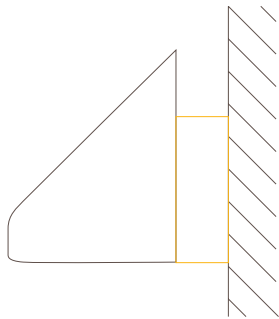

Anti-ligature Shower Track

Warning

The magnetic element of the YewdaleKestrel® bracket is POWERFUL. Handle with care. If attached to a flat steel surface it may be difficult to remove the magnet. DO NOT PLACE NEAR SENSITIVE ELECTRONIC EQUIPMENT.

YewdaleKestrel® products are designed as standalone products only. Care should be taken when assessing or arranging a room to ensure that YewdaleKestrel® products cannot be misused in conjunction with any other item, furniture or fixings in the room.

It is the responsibility of the end user or client to ensure the product is suitable for the environment it is being installed in. YewdaleKestrel® products must be fitted by a qualified professional with an up to date training certificate and in accordance with the manufacturer's instructions. Failure to do so could jeopardise the product's effectiveness as an anti-ligature system. All installations must be checked and commissioned on completion to ensure the downward forces does not exceed the maximum nor that it is breaking away below the normal force. It is highly recommended that sign off proof that the product is installed and commissioned correctly is issued to the client after installation.



For more information on installations, using the systems safely, load testing and maintenance, please scan the QR code to read our YewdaleKestrel® Policy.



Head Office:

Enterprise Way,
Wickford, Essex, SS11 8DH
Call: +44 (0)1268 570900
Email: sales@yewdale.co.uk

London Office & Showroom:

4 Sutton Lane,
London, EC1M 5PU
Call: +44 (0)203 818 5905

For more information on all
Yewdale products, please call
the sales department.

